

Shunt Active Power Filter of PI and Fuzzy Controller for Power Quality Improvement

Mrs. M. Inba Arasi ^[1], S. Ranjitha ^[2]

ME Research Scholar ^[2], Assistant Professor ^[1]

Department of Electrical & Electronics Engineering
Mahendra College of Engineering, Salem
Tamil Nadu - India

ABSTRACT

Shunt active filters are widely used in distribution system to reduce the harmonics produced by non-linear loads. The paper explained with an indirect current controlled using of shunt active power filter (APF) for improving power quality by reactive power compensation and harmonics will be filtering. The proposed APF is controlled by fuzzy controller and it is compared to the PI controller based on a voltage source inverter (VSI). The VSI is controlled with in two loops, the voltage control loop and the current control loop. The voltage control loop controls the DC link capacitor voltage and the current control loop uses hysteresis band control. And it is to shape the source of current such that it is in-phase with and of the same shape as the input voltage. The major advantage of the proposed APF by fuzzy controller. It is the reference current for power quality improvement. It is generated from the DC link capacitor voltage. This work presents and compares the performance of PI and fuzzy controller. **Keywords:-** Active Power Filter, Harmonic Filtering, Hysteresis Band Control, Power Quality, Reactive Power Compensation

I. INTRODUCTION

There has been a continuous rise of nonlinear loads over the years due to intensive use of power electronic control in industry as well as by domestic consumers of electrical energy. The utility supplying these nonlinear loads has to supply large vars. Moreover, the harmonics generated by the nonlinear loads pollute the utility. The basic requirements for compensation process involve precise and continuous var control with fast dynamic response and on-line elimination of harmonics. To satisfy these criterion, the traditional methods of var compensation using switched capacitor and thyristor controlled inductor coupled with passive filters are increasingly replaced by active power filters (APFs) and hybrid APFs. The hybrid APFs improve the characteristics of passive filters with smaller rated APFs. The majority of the reported APFs and hybrid APFs use a var calculator to calculate the reactive current drawn by the load and accordingly a reference current is generated. The compensator current is made to follow the reference current for the required compensation. This method exhibits good current profile and fast dynamic response; however the generation of reference current is a complicated process. In the proposed indirect current controlled APF, the reference current is generated from the DC link capacitor voltage directly, without calculating the reactive current drawn by the

load. As the reference current in the proposed APF is generated from the DC link capacitor voltage, without calculating the reactive current drawn by the load, the compensation process is straight forward and simple as compared to the control techniques of conventional APFs. For higher rated nonlinear loads; multilevel inverters (MLIs) can be used to control the output voltage and reduce undesired harmonics of MLIs, sinusoidal PWM techniques have been conventionally used in MLIs. The major complexity associated with such methods is to solve the nonlinear transcendental equations characterizing the harmonics using iterative techniques. However, this is not suitable in cases involving a large number of switching angles if good initial guess is not available. Another approach based on mathematical theory of resultant, wherein transcendental equations that describe the selective harmonic elimination problem are converted into an equivalent set of polynomial equations and then mathematical theory of resultant is utilized to find all possible sets of solutions for the equivalent problem has also been reported. However, as the number of harmonics to be eliminated increases (up to five harmonics), the degrees of the polynomials in the equations become so large that solving them becomes very difficult. The evolutionary algorithm can be applied for computing the optimal switching angles of the MLI with the objective of optimizing the individual harmonics to allowable limits.

The proposed indirect current controlled shunt APF is shown in Fig. 1. and 3It has two control loops, the voltage control loop and the current control loop. The voltage control loop regulates the average value of the DC link capacitor voltage (V_c). The sensed DC link capacitor voltage is sent to a low pass filter (LPF) to remove the ripples present in it. The voltage thus obtained is compared with a reference DC voltage ($V_{c,ref}$) and the error is fed to a PI and fuzzy

controller. The output of the PI and fuzzy controller is the amplitude (k) of the current, which is used to derive the reference current. The derived reference current is compared with the source current in the current control loop for generating gate signals for the switches of the voltage source inverter (VSI) of the APF. Hysteresis band control has been used in the current control loop of the proposed APF.

Nomenclature			
V_c	DC link capacitor voltage	i_{comp}	compensation current of the APF
$V_{c,min}$	minimum DC link capacitor voltage	i_{load}	load current
$V_{c,ref}$	reference DC voltage	i_s	source current
V_s	AC system voltage	i_{ref}	reference current
v_{comp}	compensating voltage	s	switching function
V_{comp}			
1	fundamental component in v_{comp}	x	supply frequency
Q	var supplied by the APF	x_s	switching frequency
L	inductor in series with the APF	$x_{s,max}$	maximum switching frequency
R	resistance of inductor L	HB	hysteresis band
C	DC link capacitor		

II. INDIRECT CURRENT CONTROLLED APF

The VSI of a single-phase indirect current controlled shunt APF is shown in Fig. 2. The VSI is controlled to produce a fundamental terminal voltage in-phase with the AC system voltage. When the fundamental inverter terminal voltage is more than the RMS value of AC system voltage V_s , a leading current is drawn from the AC system and when the inverter

terminal voltage is less than V_s , a lagging current is drawn from the AC system. The magnitude of the inverter terminal voltage depends on the DC link capacitor voltage V_c .

By controlling the gate signals of the switches, the inverter terminal voltage can be made to lag or lead the AC system voltage, By suitable operation of the switches, a voltage v_{comp} having a fundamental component V_{comp1} is generated at the output of the inverter. When $V_{comp1} > V_s$, leading current (with respect to V_s) will be drawn and the inverter supplies lagging vars to the system. When $V_{comp1} < V_s$,

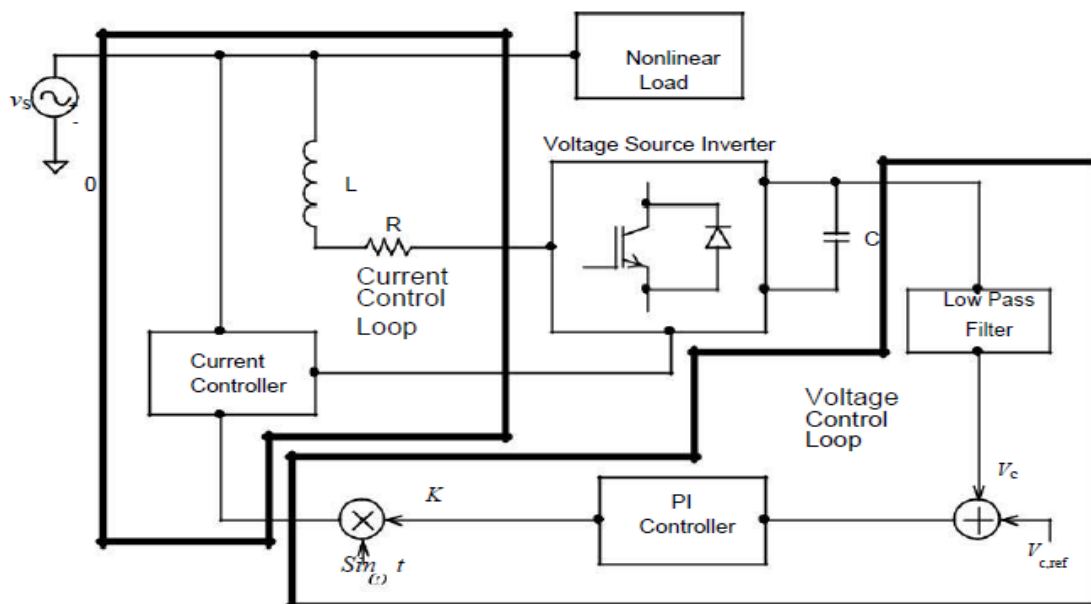

Fig. 1. Indirect current controlled shunt APF.

When $V_{comp1} = \frac{1}{4} V_s$, no current will flow into or out of the system. The var supplied by the APF is given by

$$Q = \frac{V_s |V_{comp1} - V_s|}{\sqrt{\omega^2 L^2 + R^2}} \quad (1)$$

Where L is the inductor in series with the APF, R is the resistance of inductor L and x is the supply frequency. By controlling V_{comp1} , the reactive power can be controlled.

III. CONTROL PRINCIPLE

The switches S_1, S_2, S_3 and S_4 (Fig. 2) are operated in such a way that total current drawn from the source is of the same shape as that of the source voltage V_s . This gives

$$\frac{di_{comp}}{dt} = \frac{V_s - R i_{comp} - sV_c}{L} \quad (2)$$

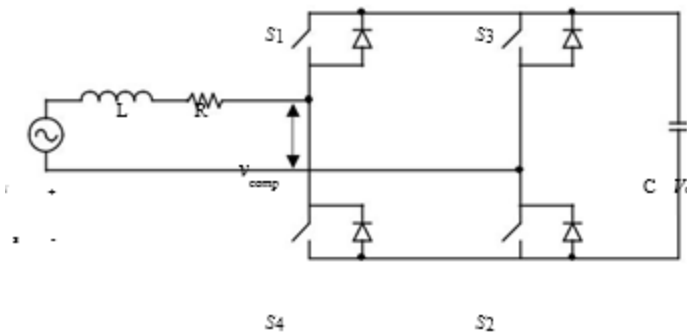

Fig. 2. Voltage source inverter

The APF forces the source current to become same in shape as the source voltage V_s . The source current i_s can be expressed in terms of compensation current of the APF, i_{comp} and load current,

$$i_{load} \text{ as } i_s = i_{comp} + i_{load} \quad (3)$$

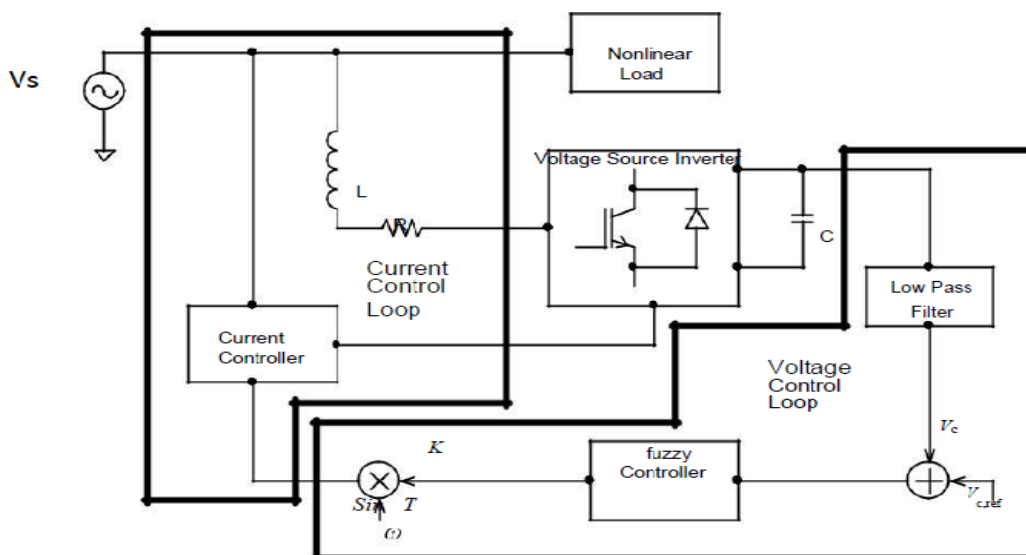

Fig. 3. Indirect current controlled shunt APF

By controlling the switching function s , (4) can be controlled. V_c is maintained at a voltage higher than V_s . This is done by the voltage control loop.

Differentiating (3) gives

$$\frac{di_s}{dt} = \left(\frac{V_s - Ri_{comp} - sV_c + L \frac{di_{load}}{dt}}{L} \right) \quad (4)$$

The dynamic stability of the indirect current controlled APF depends on its ability to keep the DC link capacitor voltage close to a reference value. The capacitor voltage control loop assumes that the active power supplied by the source is the sum of the power drawn by the load and the losses in the inverter. During the sudden increase in load power demand, this results into an increase in the capacitor error voltage, which ultimately increases the magnitude of the reference current. The increase in reference current recharges the capacitor to the reference value. Capacitor voltage decreases because the energy stored in the capacitor supplies power to the load.

IV. DESIGN OF DC LINK CAPACITOR

The DC link capacitor supplies or absorbs energy, whenever there is a sudden change in the period of the supply frequency. The DC link capacitor value is calculated from the energy balance principle. The energy stored in capacitor is equal to the energy demand of the load during the transient period.

This assumption after simplification gives the expression for calculating the value of the DC link capacitor,

$$C = \frac{2\pi V_s i_s}{\omega} \left(\frac{1}{V_c^2 - V_{c,min}^2} \right) \quad (5)$$

Where $V_{c,min}$ is the desired minimum capacitor voltage. In practice, a slightly higher capacitance value is selected to take care of the capacitor losses.

V. DESIGN OF FILTER INDUCTOR

The filter inductor must be small enough so that the injected current $\frac{di_{ref}}{dt}$ is greater than that of the reference current $\frac{di_{ref}}{dt}$ for the injected current to track the reference current. The reference current is expressed as

$$i_{ref} = k \sin \omega t \quad (6)$$

$$\max \left(\frac{di_{ref}}{dt} \right) = k\omega \quad (7)$$

The maximum $\frac{di_{ref}}{dt}$ of the reference current is determined for each harmonic component based on its amplitude and frequency. The overall maximum $\frac{di_{ref}}{dt}$ of the reference current is the highest individual $\frac{di}{dt}$. The harmonic giving the highest third harmonic for the single-phase and fifth harmonic for the three-phase nonlinear loads.

From the standard inductor differential equation, an expression can be determined assuming negligible resistance as

$$\frac{di_L}{dt} = \frac{\Delta V_L}{L} \quad (8)$$

The maximum inductance possible is used in the inverter to give the lowest average switching frequency. This in turn

reduces the electromagnetic interference and switching losses.

VI. HYSTERESIS BAND CONTROL

The hysteresis band control scheme is shown in Fig. 4. In this scheme, the switching instants occur in such a way as to force the current to remain within a hysteresis band. The switching takes place when the error exceeds a fixed magnitude hysteresis band. The control laws with respect to the switches of the VSI (Fig. 2) of the APF are as follows:

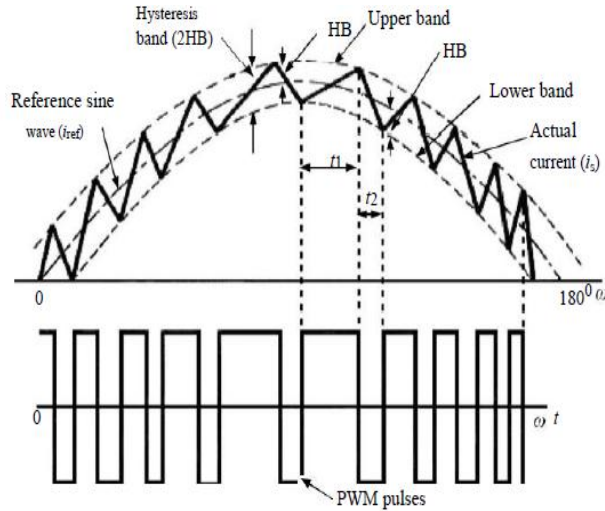

Fig. 4. Hysteresis band control.

The respective equation for switching intervals t_1 and t_2 can be written as

$$\frac{di_S^+}{dt} = \frac{V_S - R_{i\text{comp}} + V_C}{L} + \frac{di_{\text{Load}}}{dt} \quad (9)$$

$$\frac{di_S^-}{dt} = \frac{V_S - R_{i\text{comp}} - V_C}{L} + \frac{di_{\text{Load}}}{dt} \quad (10)$$

- Lowerband $\leq i_{ref} - i_s$ upper band, none of the switches are ON.
- $i_{ref} - i_s >$ upper band, S_1 and S_2 are ON.
- $i_{ref} - i_s <$ lower band, S_3 and S_4 are ON.

The relation between t_1 and t_2 can be written in terms of switching frequency of the hysteresis band, ω_s as

$$t_1 + t_2 = \frac{2\pi}{\omega_s}$$

(11)

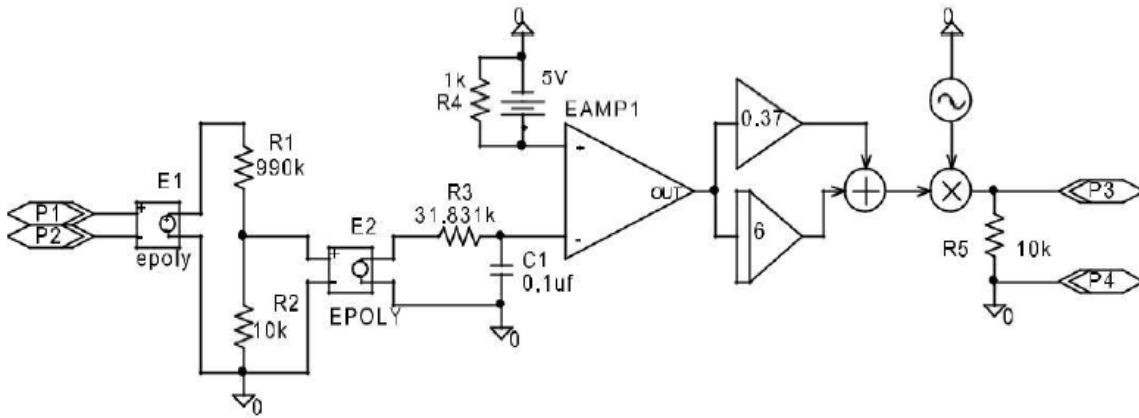

Fig 5. Voltage control loop of APF (HB1).

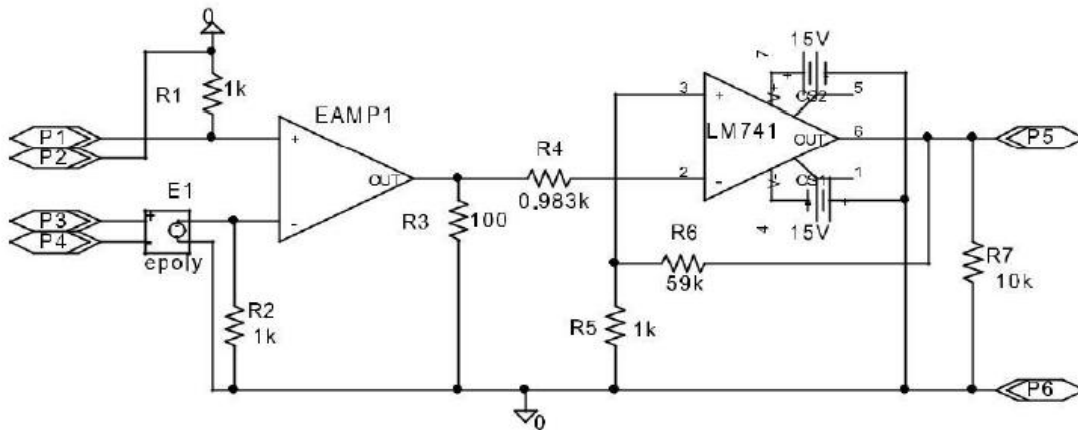

Fig. 6. Current control loop of APF (HB2).

The expression of hysteresis band, HB can be expressed as ,Where (12)

The maximum switching frequency $\omega_{s,max}$ for a specified hysteresis band can be expressed as (13)

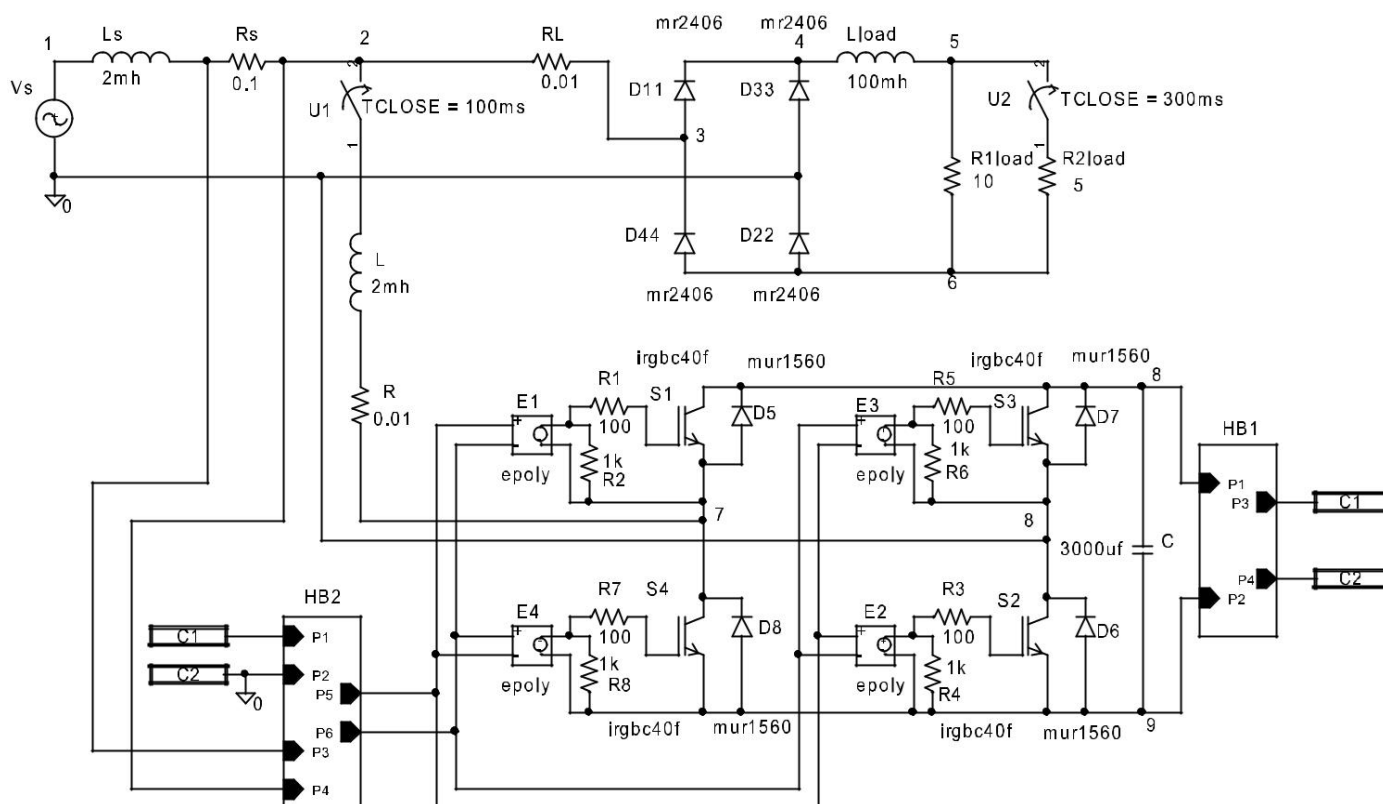
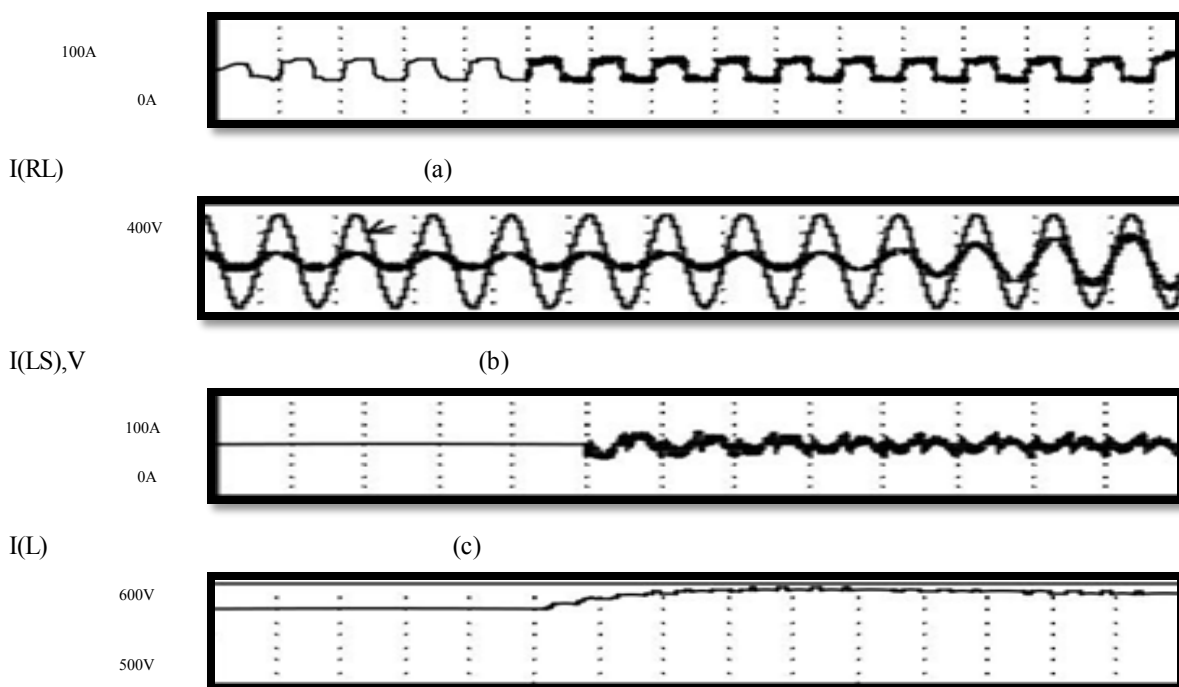

Fig.7.Simulation circuit of single phase shunt APF with diode rectifier feeding an RL load

The simulated waveforms of single phase shunt active power filter with diode rectifier feeding an RL load with PI controller are shown below.

The (a) load current $I_{(RL)}$, (b) source current $I_{(Ls)}$ and voltage at node 1 $V(1)$, (c) current supplied by APF $I_{(L)}$ and (d) DC link capacitor voltage $V(C:1) - V(C:2)$



$V(C:1) - V(C:2)$ (d) Time

Fig. 8. Simulated waveforms of single-phase shunt APF with diode rectifier feeding an RL load in PI controller.

- (a) Load current I (RL),
- (b) Source current I (Ls) and voltage at node 1 V (1),
- (c) Current supplied by APF I (L)
- (d) DC link capacitor voltage V(C: 1)–V(C: 2).

The simulated waveforms of single phase shunt active power filter with diode rectifier feeding an RL load with fuzzy controller are shown below. The (a) load current I(RL), (b) source current I(Ls) and voltage at node 1 V(1), (c) current supplied by APF I(L) and (d) DC link capacitor voltage V(C:1)–V(C:2).

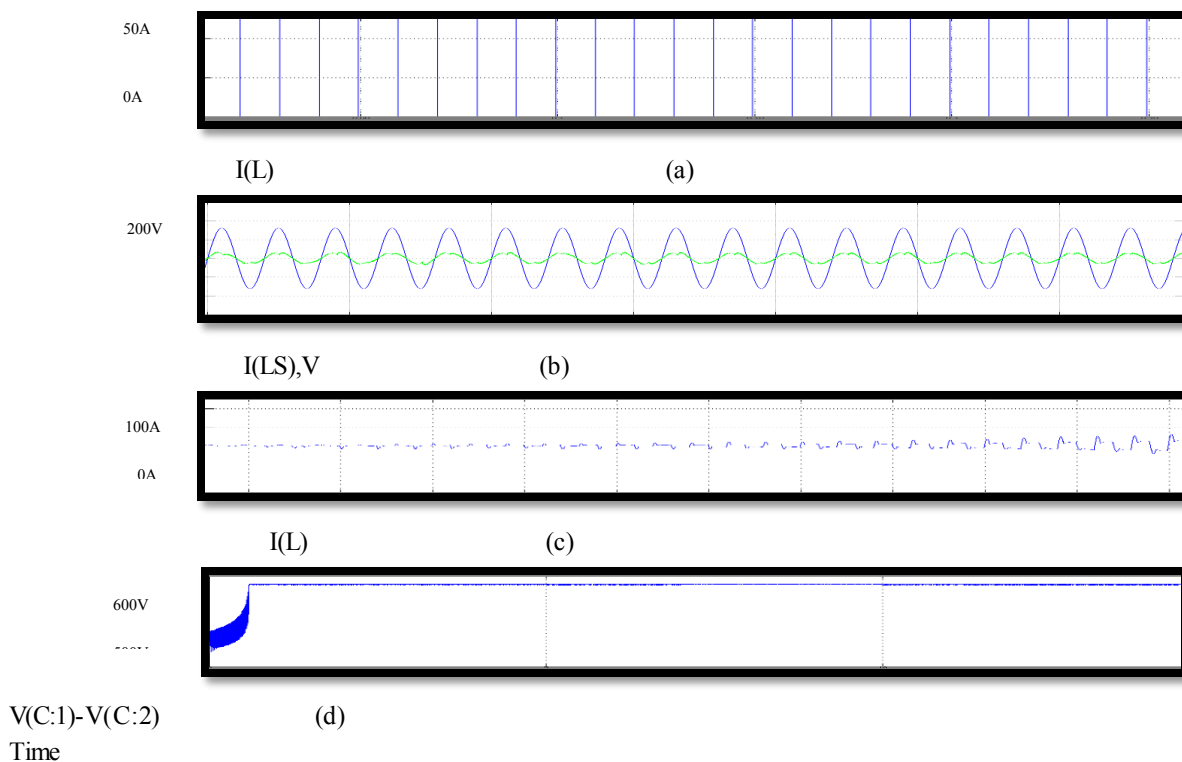

Fig. 9. Simulated waveforms of single-phase shunt APF with diode rectifier feeding an RL load in fuzzy controller.

- (a) Load current I (RL),
- (b) Source current I (Ls) and voltage at node 1 V(1)
- (c) Current supplied by APF I (L)
- (d) DC link capacitor voltage V(C: 1)–V(C: 2).

VII. SIMULATION RESULTS

The proposed indirect current controlled shunt APF has been simulated using Pspice for a 230 V, 50 Hz AC system for the cases: (1) single-phase shunt APF with diode rectifier feeding an RL load with PI controller, (2) single-phase shunt APF with diode rectifier feeding an RL load with fuzzy controller.

7.1 Single-phase shunt APF with diode rectifier feeding an RL load

The simulation circuit of single-phase shunt APF with diode rectifier feeding an RL load is shown in Fig. 9 (Rload = 10 X, R2load = 5 X and L load = 100 mH). The control loops HB1 and HB2 are same as that. The simulated waveforms of I (RL), I(Ls), V(1), I(L) and V(C:1)–V(C:2) are shown in Figs. 8 & 9(a)–(d). The harmonic spectra of I (RL) and I(Ls) after step change in load at 300 ms are shown in Figs. 4(a) and (b).

VIII. DISCUSSIONS ON SIMULATION RESULTS

The individual harmonic components in load current $I(L)$, source current $I(L_s)$ and % total harmonic distortion (THD) for the cases discussed. THD (%) of the source currents for all the two cases are well below 5%, the harmonic standards defined in IEEE Standard 519–1992. It may be observed from the simulation studies that the source current and voltage at the point of common coupling is distorted at the instant of connecting the APF. However, it does not affect the performance of APF and the source current becomes sinusoidal after connecting the APF in PI and fuzzy controller.

It may be noticed from the simulation results that the dynamic response time of the proposed indirect current controlled shunt APF is two cycles. The reason behind this is that a LPF is used to eliminate the ripple from the sensed DC link voltage. Inclusion of a LPF introduces a finite delay in the control process. In addition, the DC link capacitor takes some time to respond to the change in load conditions.

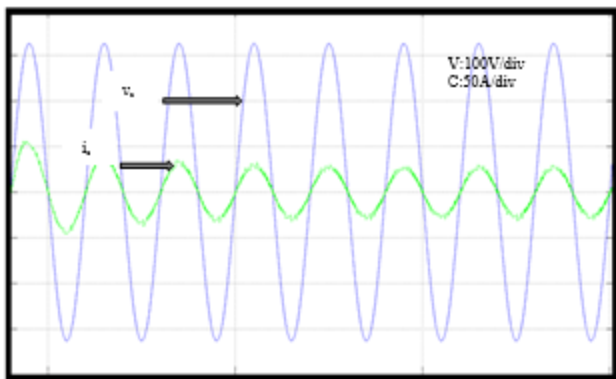

Fig.10.Simulated waveforms of source voltage v_s and source current i_s waveforms before connecting of APF in PI controller.

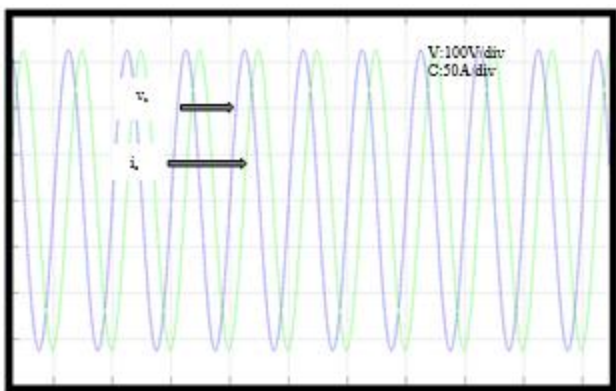

Fig.11.Simulated waveform of source voltage v_s and source current i_s waveforms before connecting of APF in fuzzy controller

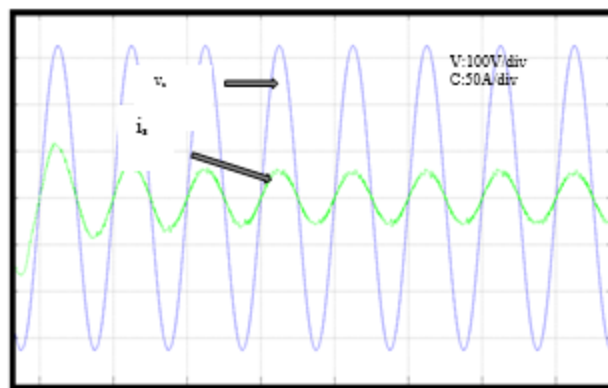

Fig.12.Simulated waveform of source voltage v_s and source current i_s waveforms after connecting of APF in PI controller.

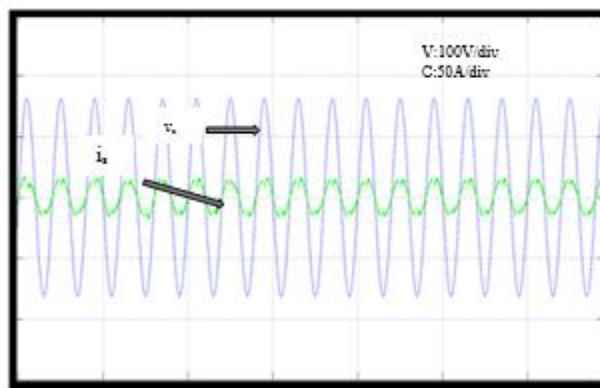

Fig.13.Simulated waveform of source voltage v_s and source current i_s waveforms after connecting of APF in fuzzy controller.

IX. CONCLUSION

An indirect current is controlled by shunt APF has been proposed for improving power quality and harmonic filtering. The mathematical background of the indirect current will be controlled shunt APF using of the hysteresis band control has been used. Simulations have been carried out using Pspice for single-phase indirect current controlled by shunt APFs. And it is for different types of nonlinear loads. A single-phase indirect current controlled shunt APF prototype has been tested and developed in the laboratory to analyzed some of the simulation results. As the reference current in the proposed APF in fuzzy controller has been generated by regulating the DC link capacitor voltage using PI and fuzzy controller. Without calculating the reactive current drawn by the load, the compensation process is straight forward and simple as compared to conventional APFs. After compensation, the source current is sinusoidal and it is phase with the supply voltage. It compensates both harmonics and reactive power simultaneously. Finally, the

simulation results of with and without filter has been compared.

REFERENCES

- [1] Gyugyi L. Reactive power generation and control by thyristor circuits. *IEEE Trans Ind Appl* 1979;15(5):521–32.
- [2] Gyugyi L, Taylor Jr ER. Characteristics of static, thyristor-controlled shunt compensators for power transmission system applications. *IEEE Trans Power Apparatus Syst* 1980;99(5):1795–804.
- [3] Jin H, Goós G, Lopes L. An efficient switched-reactor-based static var compensator. *IEEE Trans Ind Appl* 1994;30(4):998–1005.
- [4] Karymov RR, Ebadian M. Comparison of magnetically controlled reactor (MCR) and thyristor controlled reactor (TCR) from harmonics point of view. *Int J Electr Power Energy Syst* 2007;29(3):191–8.
- [5] Mahanty R. Large value AC capacitor for harmonic filtering and reactive power compensation. *IET Gen Transm Distrib* 2008;2(6):876–91.
- [6] Mahanty R. Modified static VAR compensator using a large value AC capacitor. *Elect Power Syst Res* 2010;80(2):240–7.
- [7] Abdusalam M, Poure P, Karimi S, Saadate S. New digital reference current generation for shunt active power filter under distorted voltage conditions. *Elect Power Syst Res* 2009;79(5):759–65.
- [8] Vardar K, Akpınar E, Sürgevil T. Evaluation of reference current extraction methods for DSP implementation in active power filters. *Elect Power Syst Res* 2009;79(10):1342–52.
- [9] Singh GK, Singh AK, Mitra R. A simple fuzzy logic based robust active power filter for harmonics minimization under random load variation. *Elect Power Syst Res* 2007;77(8):1101–11.
- [10] EL-Kholy EE, EL-Sabbe A, El-Hefnawy A, Mharous HM. Three-phase active power filter based on current controlled voltage source inverter. *Int J Electr Power Energy Syst* 2006;28(8):537–47.